

S5-50/90, S6-65/66/70/75/80/90, 6S-800/1000/1200 TD/TO
(Volvo ZTO 1006), 6AS 800/1000TO

Posterior Neumático (1:1)
Rear Pneumatic



Descripción Description

Toma de fuerza directa, relación interna 1:1 para montar bombas ISO 4 taladros. Accionamiento neumático, montaje sobre el registro frontal de 4 taladros de la caja de cambios. Indicador de funcionamiento opcional.

Power Take-off direct, internal ratio 1:1 to connect Iso 4 bolts pumps. Pneumatic shifting, mounting on rear 4 bolts-window of the Gearbox. Optional: Passing contact switch or presure switch

Datos Principales Main Data

Par nominal Torque (Nm)	800
Potencia (1000 r.p.m.) Power (HP) 1000 r.p.m	114 C.V // 85 kW
Lado de montaje Mounting position	Posterior Rear
Sentido de giro de la bomba Pump rotation	Izquierdo Anti Clockwise
Peso Weight (Kg)	2,4
Relación motor - Toma de Fuerza Engine to PTO ratio	ANEXO ATTACHMENT

Códigos y Combinaciones Part Numbers and Combinations

Tipos de salida Output types	Eje Shaft	Plato Flange	Bomba Pump (DIN 5462)
Accionamiento neumático Pneumatic shifting		1015702	1015703

S5-50/90, S6-65/66/70/75/80/90, 6S-800/1000/1200 TD/TO
(Volvo ZTO 1006), 6AS 800/1000TO

Posterior Neumático
Rear Pneumatic

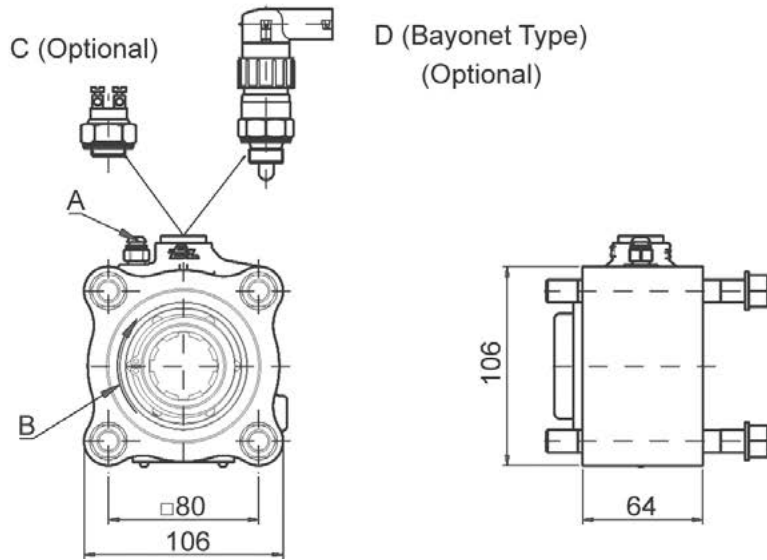

Notas Notes

Notas		Notes	
A	Toma de aire, rosca 1/8" GAS	A	Air connection, thread 1/8" BSP
B	Sentido de giro	B	Rotation
C	Interruptor neumático. (100070018)	C	Pressure switch. P/N 100070018
D	Interruptor de contacto. (9024999)	D	Passing contact switch. P/N 9024999

Tipos de Salida Output Types

Adaptador Plato / Flange Adapter

SAE:	1100	7015504
	1300	
	1400	7015604
DIN:	90	7015804
	100	7015704

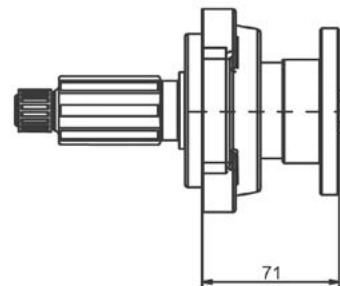
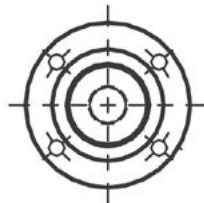

S5-50/90, S6-65/66/70/75/80/90, 6S-800/1000/1200 TD/TO
(Volvo ZTO 1006), 6AS 800/1000TO

Posterior Neumático
Rear Pneumatic

CAJA	GEARBOX	RELACIÓN	RATIO
	/ 5.30		1: 0,653
	/ 5.50		1: 0.615
	/ 6.20		1: 0,545
	/ 6.61		1: 0,510
S5-50	/ 6.61 + GV80 / 5.30	Larga High	1: 0,637
		Normal Normal	1: 0,510
	/ 8.02		1: 0,422
	/ 8.02 + GV80 / 6.20	Larga High	1: 0,545
		Normal Normal	1: 0,421
S5-90GP	/ GPA		1: 0,890
	/ 6.37		1: 0,650
	/ 6.70		1: 0,620
S6-65	/ 7.0 + GV70 / 7.67	Larga High	1: 0,456
		Normal Normal	1: 0,365
	/ 7.40		1: 0,562
	/ 7.52		1: 0,555
	/ 9.00		1: 0,462
	7.97 + GV80 / 6.70	Larga High	1: 0,620
		Normal Normal	1: 0,525
	/ 9.00 + GV80 / 6.70	Larga High	1: 0,620
	Normal Normal	1: 0,462	
S6-66	/ 9.00 + GV80 / 7.52	Larga High	1: 0,554
		Normal Normal	1: 0,462
	/ 7.36-1.0		1: 0,522
	/ 9.06-1.0		1: 0,416
S6-70	/ 6.8		1: 0,514
	/ 6.8+GV70 / 5.71	Larga High	1: 0,612
		Normal Normal	1: 0,514
	/ 7.36		1: 0,478
S6-75	/ 7.92		1: 0,441
	/ 9.03		1: 0,387
	/ 9.59		1: 0,365
	/ 6.70+GV80 / 7.52	Larga High	1: 0,620
	Normal Normal	1: 0,554	
S6-80	/ 5.03		1: 0,780
	/ 5.66		1: 0,740

CAJA	GEARBOX	RELACIÓN	RATIO
	/ 5.66 + GV80 / 7.52	Larga High	1: 0,738
		Normal Normal	1: 0,556
	/ 6.10		1: 0,688
	/ 6.70		1: 0,620
S6-80	/ 6.7 + GV80 / 5.30	Larga High	1: 0,787
		Normal Normal	1: 0,620
	/ 6.90		1: 0,515
	/ 7.35	Larga High	1: 0,552
	/ 7.41		1: 0,563
	/ 7.53		1: 0,555
	/ 7.67		1: 0,540
	/ 7.67 + GV80 / 6.70	Larga High	1: 0,622
		Normal Normal	1: 0,543
	/ 7.90		1: 0,525
	/ 9.00		1: 0,460
	/ 9.00 + GV80 / 5.30	Larga High	1: 0,787
		Normal Normal	1: 0,462
	/ 9.00 + GV80 / 7.48	Larga High	1: 0,562
		Normal Normal	1: 0,462
	/ 9.00 + GV80 / 7.52	Larga High	1: 0,554
		Normal Normal	1: 0,462
	/ 5.67		1: 0,750
	/ 5.74		1: 0,740
	/ 6.37		1: 0,740
	/ 6.98		1: 0,612
	/ 7.03		1: 0,603
S6-90	/ 7.03 + GV90 / 5.67	Larga High	1: 0,750
		Normal Normal	1: 0,603
	/ 7.03 + GV90 / 5.74	Larga High	1: 0,735
		Normal Normal	1: 0,600
	/ 7.40		1: 0,575
	/ 9.01		1: 0,470
	/ 9.01 + GV90 / 7.40		1: 0,573
	6S800TO / 6.58 - 0.78 (Volvo ZTO 1006)		1: 0,471
	6AS800TO / 6.58 - 0.78		1: 0,530
	6AS1000TO / 6.75 - 0.78		1: 0,530
	6S1000TO / 6.75 - 0.78		1: 0,530
	6S1200TD / 7.72 - 1.00		1: 0,540
	6S1200TO / 6.75 - 0.83		1: 0,620